

# Walkabout MOTHER BINS

---

WMB 4000+ Eastern Grey



**Walkabout**  
MOTHER BINS



**BREAK THE GRAIN HARVEST  
BOTTLENECK**

# OPTIMIZE YOUR HARVEST EFFICIENCY WITH A WALKABOUT MOTHER BIN

Grain farmers can benefit from the Walkabout Mother Bin's inventive design, which provides over 4000 bushels of portable in-field storage. This design is specifically intended to eliminate any bottlenecks that may occur during the harvest season, allowing for a smooth and stress-free process that maximizes profit margins.

## REDUCE LABOR COSTS & MANAGE FEWER PEOPLE

A mother bin can reduce the need for extra grain carts or trucks, which leaves you with fewer drivers on the field. Our remote control technology allows a single operator to operate the auger and unload grain.

## HARVEST FASTER

A mother bin prevents delays that occur when combines and grain carts are forced to stop and wait for trucks to return.

## BREAK THE HARVEST BOTTLENECK

The Walkabout Mother Bin guarantees the ability to continue (or extend) harvesting time if problems arise because of slow unloading at the elevator or on-farm storage, if elevators close, or if the distance from farm or elevator is too far for trucks to keep grain away from combines.





**"THE NEXT TIME YOU ARE SITTING  
IN YOUR COMBINE IN THE MIDDLE  
OF YOUR FIELD, IDLE, WITH A FULL  
TANK OF GRAIN, THINK ABOUT HOW A  
WALKABOUT MOTHER BIN WOULD HAVE  
PREVENTED THIS HUGE LOSS OF DAILY  
PRODUCTIVITY."**





# 4,000+ BUSHELS OF IN-FIELD, MOBILE, GRAIN STORAGE

58' long x 13'9" wide x 12'11" high / Minimum 250hp+ required

The Walkabout Mother Bin is essential harvest equipment offering a large, portable, in-field grain storage solution (4,000-bu capacity). This amazing concept saves time, money and labor while increasing harvest and grain handling efficiency. Walkabout Mother Bins are made, and owned, in the USA.

- 4,000 bushel capacity
- Split front and rear flow gates for blending grain
- Up to 900 bushel-per-minute unload rate
- 4-way adjustable auger spout
- Rear access door
- Full length clean out doors
- AGRI-COVER® Electric Roll Tarp
- 22" Elmer's unload auger
- Camera system
- Self-steering front and force-steering rear axles





The Walkabout Mother Bin is fully customizable to suit the needs of each individual operation. Customization makes a bin its most efficient while increasing the owner's return on investment.

Options include:

- Vibrator
- Remote unload system
- Scale system
- Agrimatics available
- External scale display
- Low auger unload package



**"I DISCOVERED THE WALKABOUT WEBSITE AND WITHIN 24 HOURS CRYSTAL, THEIR SALES DIRECTOR, WAS SITTING IN THE COMBINE NEXT TO ME, GETTING A LOOK AT THE FARM TO SEE IF A WALKABOUT MOTHER BIN WOULD WORK FOR US, AND IT DID. IT'S CHANGED OUR HARVEST. I'M SUPER GRATEFUL."**

Jason Hill, Pacific NorthWest, Mother Bin Owner Since 2020

**"PREVIOUSLY, WE WAITED FOR TRUCKS TO TURN AROUND AT OUTDATED DRYERS, CAUSING DELAYS. WITH THE MOTHER BIN, EVERYTHING FLOWS SMOOTHLY, WITH ONE CENTRAL LOCATION FOR DUMPING. THE TURNAROUND TIME IS QUICKER, AND WE CAN CUT MORE LOADS PER DAY, EVEN BEFORE A HURRICANE HITS. IT'S A NO-BRAINER."**

Halley Moor, Southeast Texas, Mother Bin Owner Since 2022

**"THE MOTHER BIN ALLOWED US TO REDUCE THE NUMBER OF TRUCKS WE OWN AND COMBINE MORE GRAIN FASTER BECAUSE THE COMBINES NEVER STOP. WE FARM WITH LESS EQUIPMENT AND FINISH EARLIER THAN BEFORE AND IT'S BECAUSE OF THE MOTHER BIN. WE RUN LIKE CLOCKWORK."**

Peyton Potter, Greenville, MS, Mother Bin Owner Since 2016

**"IT WAS LIKE ADDING ANOTHER COMBINE. IT REALLY PICKED UP THE SLACK BECAUSE OF THE EXTRA SURGE CAPACITY. WE WERE ABLE TO FINISH FIELDS IN THE EVENING AFTER THE SEMIS WERE DONE LOADING. IF THE SEMIS HAD ISSUES OR BREAKDOWNS WE STILL DIDN'T HAVE TO SHUT DOWN THE COMBINE BECAUSE WE HAD EXTRA CAPACITY FOR STORAGE."**

Keegan Jones, Pendleton, OR, Mother Bin Owner Since 2020



# THE SWISS ARMY KNIFE OF EQUIPMENT

As efficiency becomes more and more important in operations, the Mother Bin really is a Swiss army knife piece of equipment that can be used several times during the year to help solve many bottleneck and labor issues.

## EMPTY OR FILL GRAIN BAGS

Along with the combine(s), keeping the bagger moving is essential to efficiency. By placing the Mother Bin next to the bagger while filling, the grain cart is never delayed in returning to the combine(s). When emptying, the Mother Bin can move with the bagger so it never has to stop.

## USE AS A SEED TENDER

With 4000-bushel capacity, seed trucks are able to tender out of the bin while being positioned in a central location during planting time.

## BLEND GRAIN

With the Walkabout Mother Bin, users are able to blend grain to get the desired moisture content by using the split front and rear flow gate feature.

## WEATHER PROTECTION

When inclement weather is approaching, users can get their commodity out of the field and protected.

## REDUCE SOIL COMPACTION

The Mother Bin allows users to run smaller grain cart(s) and smaller tractors resulting in less compaction. Less soil compaction leads to higher production and less need for tillage or fertilizer to boost production.



**Walkabout Mother Bins are made in the USA from solid steel. We deliver anywhere in the United States or Canada, coast to coast.**

# DIMENSIONS

Maximum Width	13' 8"
Maximum Height (for transport)	13' 4"
Height of top of bin side	12' 8"
Length of bin	48'
Overall length	58'
Length of pull	6' 4"
Auger height to tip down	15' 1"
Auger width to spout	8' 9"
Overall auger height	19' 6"
Tire size	425/65R 22.5

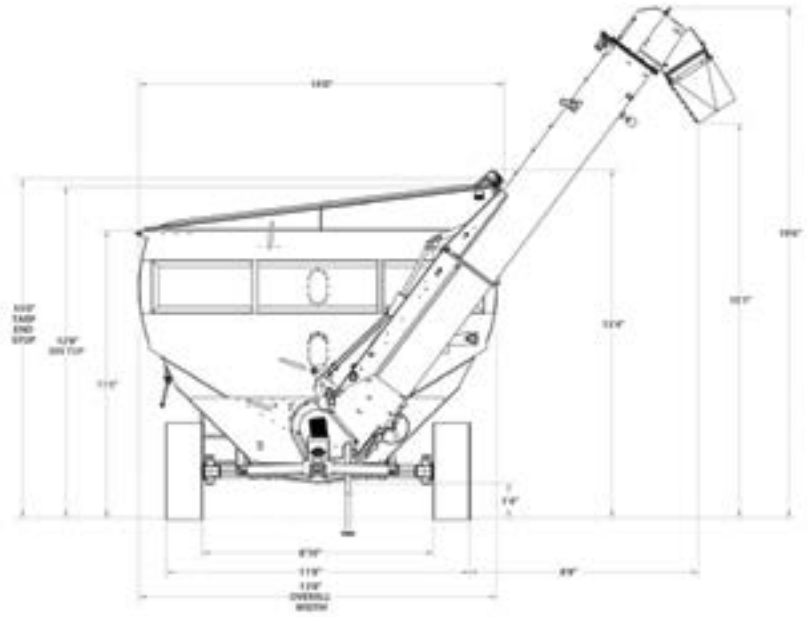

**OUR MISSION AT WALKABOUT MOTHER BINS IS TO IMPROVE  
THE LIVES OF GRAIN FARMERS.**



**800-437-9702**  
***feinc.com***